



4310(W)

CONDUCTIVITY CELL



a xylem brand

Contact YSI
1725 Brannum Lane
Yellow Springs, OH 45387 USA
Tel: +1 937-767-7241
800-765-4974
Email: environmental@ysi.com
Internet: www.ysi.com

Copyright © 2017 Xylem Inc.

1 Overview

1.1 Structure and function

Structure

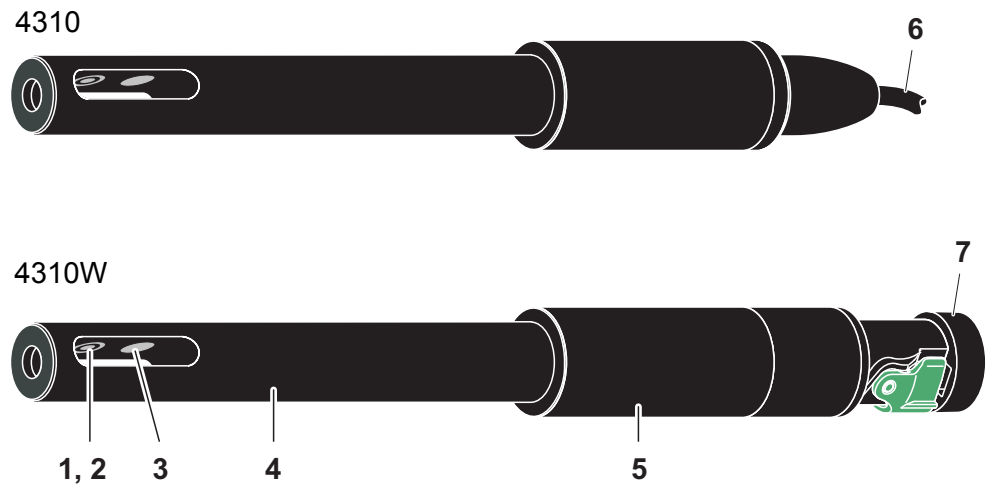

1	Voltage electrode (inside, 2x)
2	Current electrode (ring, 2x)
3	Temperature sensor in graphite enclosure
4	Shaft
5	Connecting head with active electronics
6	Connection cable (4310)
7	IDS plug (4310W)

Automatic sensor recognition

The sensor electronics with the stored sensor data is in the connecting head. The data include, among other things, the sensor type and series number. With each calibration, the calibration data is written in the sensor and the calibration history is recorded. The data is recalled by the meter when the sensor is connected and is used for measurement and for measured value documentation. Storing the calibration data in the sensor ensures that the correct cell constant is automatically used if the sensor is operated with several meters.

The digital transmission technique guarantees the failure-free communication with the meter even with long connection cables. If the sensor firmware is enhanced by YSI, it can be updated via the meter.

1.2 Recommended fields of application

- On site measurements in rivers, lakes and wastewater
- Fish farming
- Ground water measurements
- Applications in water laboratories

Due to the use of high performance PEEK material for the connection technology 4310 has an improved chemical resistance, especially in acid media (eg. As electroplating baths).

NOTE

Concentrated or strong oxidizing acids and organic solvents can damage or destroy the sensor.

2 Measuring / Operation

2.1 Commissioning

Scope of delivery

- Conductivity measuring cell 4310(W)
- Operating manual

Commissioning

Connect the electrode to the meter.

4310	<ul style="list-style-type: none"> – via the sensor cable to a free IDS connector on the meter
4310W	<ul style="list-style-type: none"> – via a connecting cable (accessory) to a free IDS connector on the meter or – wireless via an IDS WA-S adapter (accessory) to a WA-capable meter <p>Accessories for the connection of the 4310W sensor to the meter: See chapter 6 WEAR PARTS AND ACCESSORIES.</p> <p>Opening and closing the IDS plug connection, see section 2.2 OPENING AND CLOSING THE IDS PLUG CONNECTION (4310W).</p>

2.2 Opening and closing the IDS plug connection (4310W)

This section only applies to the IDS plug variant, 4310W.

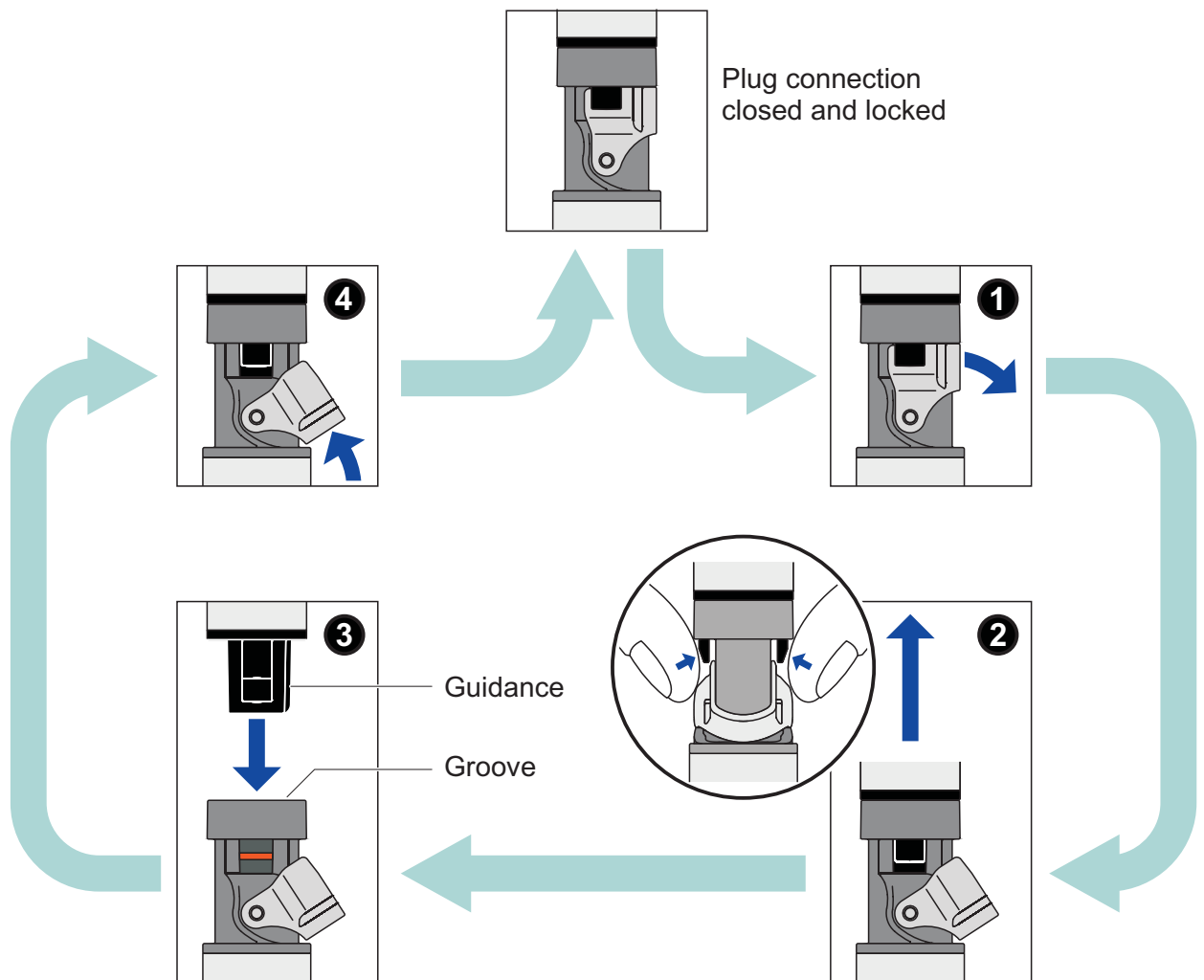

Opening the plug connection

- If necessary, clean the plug connection
- Open the locking device (step 1)
- Use your thumb and index finger to press the clips of the connector together, and pull the connector out of the plug (step 2).

Closing the plug connection

- Make sure that the plug connection is completely dry and clean.
- Align the guidance of the connector with the groove in the plug and insert the connector in the unlocked plug until it catches (step 3).
- Close the locking device (step 4).

3 Cleaning

NOTE

Prior to cleaning, disconnect the sensor from the meter.

Outside cleaning

We recommend to clean the sensor thoroughly, especially before measuring low conductivity values.

Contamination	Cleaning procedure
Lime sediments	Immerse in acetic acid for 5 minutes (volume share = 10 %)
Fat/oil	Clean with warm water that contains washing-up liquid

After cleaning, thoroughly rinse with deionized water and recalibrate if necessary.

Aging of the conductivity measuring cell

Normally, the conductivity measuring cell does not age. Special measuring media (e.g. strong acids and bases, organic solvents) or temperatures that are too high may considerably reduce its lifetime or lead to damage. The warranty does not cover failure caused by measuring conditions and mechanical damage.

Disposal

We recommend to dispose of the measuring cell as electronic waste.

4 What to do if...

Error symptom	Cause	Remedy
No temperature or conductivity display	<ul style="list-style-type: none"> - No connection between meter and conductivity measuring cell - Cable defective 	<ul style="list-style-type: none"> - Establish connection between meter and conductivity measuring cell
Measurement delivers implausible conductivity values	<ul style="list-style-type: none"> - Measuring range exceeded - Contamination in the area of the electrodes - Electrodes damaged 	<ul style="list-style-type: none"> - Make sure the correct sensor is being used for the application - Clean the conductivity measuring cell (see section 3). - Return the sensor
Incorrect temperature display	<ul style="list-style-type: none"> - The temperature sensor is not immersed deep enough in the measuring solution - Temperature sensor defective 	<ul style="list-style-type: none"> - Observe the minimum immersion depth - Return the conductivity measuring cell

5 Technical data

5.1 General data

General features	Measuring principle	Four-electrodes measurement
	Cell constant	$0.475 \text{ cm}^{-1} \pm 1.5 \%$
	Temperature sensor	Integrated NTC 30 (30 k Ω at 25 °C / 77 °F)

Dimensions (in mm)

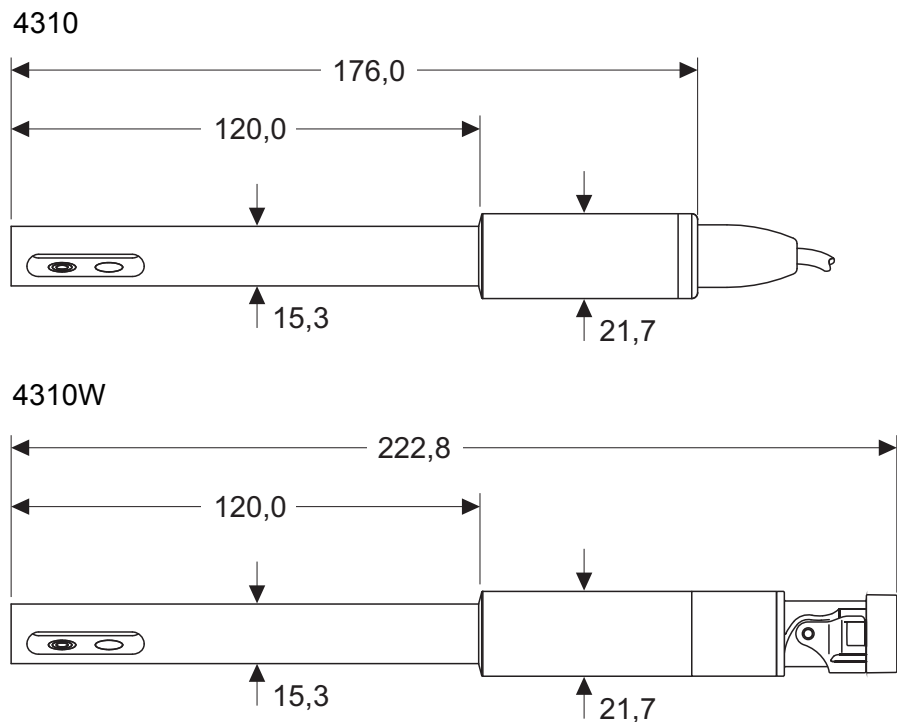

Weights	4310	60 g (without cable)
	4310W	65 g
Weight	Approx. 60 g (without cable)	
Materials	Shaft	Epoxy
	Connection head	POM
	Connection head	4310(W):POM
	Conductivity electrodes	Graphite
	Thermistor enclosure	Graphite
Connection cable	Lengths	4310: 1,5 / 3 m 4310W: 1,5 / 3 m
	Diameter	4.3 mm

	Smallest allowed bend radius	Fixed installation:20 mm Flexible use:60 mm
	Plug type	Socket, 4 pins
IDS plug (4310W)	Connection type	4-pole, watertight plug connection with lock, reverse polarity protected
	Materials	<ul style="list-style-type: none"> ● Synthetic materials: Glass fiber reinforced Noryl, TPU, TPC-ET, POM, PEEK, PBT ● O-ring: FPM ● Contacts gold-plated
Pressure resistance	Sensor with connection cable	IP 68 (2.5 x 10 ⁵ Pa or 2.5 bar)
	Cable plug (4310)	IP 67 (when plugged in)
<p>The 4310(W) meets the requirements according to article 3(3) of the directive, 97/23/EC ("pressure equipment directive").</p>		
Measurement conditions	Conductivity measuring range	1 μS/cm ... 2 S/cm
	Temperature range	-5 ... 70 °C (100 °C) (23 ... 158 °F (212 °F))
	Max. admissible overpressure	4310:2,5 x 10 ⁵ Pa (2,5 bar) 4310W:1 x 10 ⁶ Pa (10 bar)
	Minimum depth of immersion	36 mm
	Maximum depth of immersion (at temperature)	Whole sensor + cable up to 70 °C (158 °F) Sensor shaft only (=120 mm) up to 100 °C (212 °F)
	Operating position	Any
Storage conditions	Recommended storing method	In air
	Storage temperature	0 ... 50 °C
Characteristic data on delivery	Temperature responding behavior	t ₉₉ (99 % of the final value display after) < 20 s
	Accuracy of the temperature sensor	± 0,2 K

5.2 Measuring ranges, resolution, accuracy

Measured parameter	Measuring range	Resolution
æ [μ S/cm]	0.0 ... 199.9	0.1
	200 ... 1999	1
æ [mS/cm]	2.00 ... 19.99	0.01
	20.0 ... 199.9	0.1
	200 ... 2000	1
ρ (Resistivity) [Ohm*cm]	0.50 ... 19.99	0.01
	20.0 ... 199.9	0.1
	200 ... 1999	1
ρ (Resistivity) [kOhm*cm]	2.00 ... 19.99	0.01
	20.0 ... 199.9	0.1
	200 ... 1999	1
ρ (Resistivity) [MOhm*cm]	2.00 ... 19.99	0.01
SAL	0.0 ... 70.0 according to IOT table	0.1
TDS	0 ... 1999 mg/l	1
	2.00 ... 19.99 g/l	0.01
	20.0 ... 199.9 g/l	0,1
T [°C]	- 5.0 ... + 100.0	0,1

5.3 Accuracy of the IDS measuring technique

Measured parameter	Accuracy (± 1 digit)
æ, ρ , SAL, TDS	± 0.5 % of measured value
T [°C]	± 0.1

6 Wear parts and accessories

Connection cable 4310W - meter

Description	Model	Order no.
IDS connection cable, 1.5 m	IDS-CABLE-1.5	903 850Y
IDS connection cable, 3 m	IDS-CABLE-3	903 851Y

Radio connection 4310W - meter

Description	Model	Order no.
WA capable IDS meter + radio module for IDS meter	see Internet	
Radio module for plug head sensor	IDS WA-S	108 141Y

7 Contact Information

7.1 Ordering & Technical Support

Telephone: (800) 897-4151
(937) 767-7241
Monday through Friday, 8:00 AM to 5:00 PM ET

Fax: (937) 767-1058

Email: environmental@ysi.com

Mail: YSI Incorporated
1725 Brannum Lane
Yellow Springs, OH 45387
USA

Internet: www.ysi.com

When placing an order please have the following information available:

YSI account number (if available)	Name and Phone Number
Model number or brief description	Billing and shipping address
Quantity	Purchase Order or Credit Card

7.2 Service Information

YSI has authorized service centers throughout the United States and Internationally. For the nearest service center information, please visit www.ysi.com and click 'Support' or contact YSI Technical Support directly at 800-897-4151.

When returning a product for service, include the Product Return form with cleaning certification. The form must be completely filled out for an YSI Service Center to accept the instrument for service. The Product Return form may be downloaded at www.ysi.com and clicking on the 'Support' tab.

Xylem |'zīləm|

- 1) The tissue in plants that brings water upward from the roots;
- 2) a leading global water technology company.

We're 12,500 people unified in a common purpose: creating innovative solutions to meet our world's water needs. Developing new technologies that will improve the way water is used, conserved, and re-used in the future is central to our work. We move, treat, analyze, and return water to the environment, and we help people use water efficiently, in their homes, buildings, factories and farms. In more than 150 countries, we have strong, long-standing relationships with customers who know us for our powerful combination of leading product brands and applications expertise, backed by a legacy of innovation.

For more information on how Xylem can help you, go to www.xylem.com



a **xylem** brand

YSI
1725 Brannum Lane
Yellow Springs, OH 45387
Tel: +1 937-767-7241; 800-765-4974
Fax: +1 937-767-1058
Email: environmental@ysi.com
Web: www.ysi.com

©Xylem Inc