

Wiper Brush Installation Guide

Before You Start

These instructions are relevant for NitraLED installation on EXO2 and EXO3 Sondes.

What Do You Need?

1. EXO2 or EXO3 Sonde
2. EXO NitraLED Sensor
3. EXO C/T Sensor (Wiped recommended)
4. EXO Turbidity Sensor
5. EXO Central Wiper
6. EXO2/EXO3 Alignment Ring
7. EXO NitraLED Wiper Brush
8. Kor Software*

*Make sure Kor Software is up-to-date and firmware has been updated for the sonde, wiper, and turbidity sensor.

- 1 Remove old wiper brush by loosening the set screw with a 1/20" hex key. Clean any residue from wiper shaft.

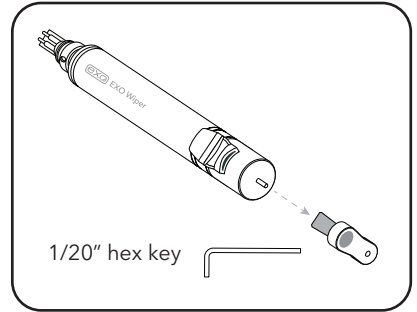

- 2 Install the Central Wiper, all sensors, and the Alignment Ring.

- **NitraLED** must be installed:
 - **EXO2:** Port 6
 - **EXO3:** Port 4
- **C/T** must be installed:
 - **EXO2:** Port 3 or Port 4
 - **EXO3:** Port 2 or Port 3

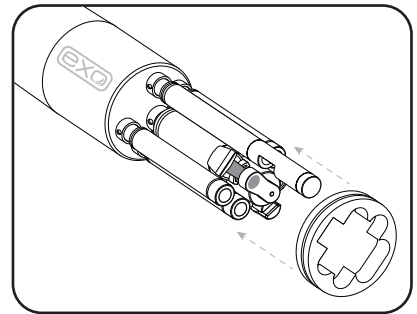

IMPORTANT: For **EXO2** configurations with NitraLED, **Port 5** should be reserved for one of the following sensors: pH, pH/ORP, ODO, or any of the Ion Selective Electrodes (ISEs). These sensors are not impaired by the Wiper Arm of the NitraLED Brush parked above Port 5.

EXO NitraLED Wiper Brush Installation

NOTE: The old wiper brush must first be removed using a 1/20" hex key.

1

The wiper shaft has a "D" shape and is sometimes referred to as the D shaft. The wiper brush fits on the D shaft only one way.

Slide the Brush onto the D shaft until fully seated.

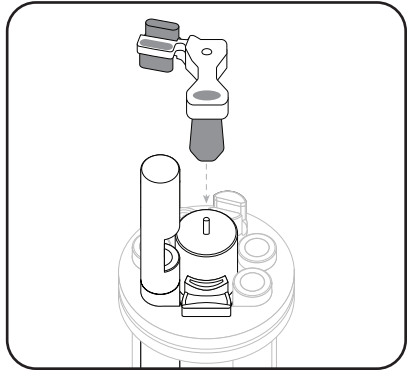

Slide Brush down until fully seated on top of the Central Wiper



DO NOT tighten the screw yet.

2

Manually rotate the Brush counter-clockwise until the Wiper Arm is seated within the sensing window of the NitraLED Sensor.

NOTE: Be careful not to use too much force while rotating the brush by hand.

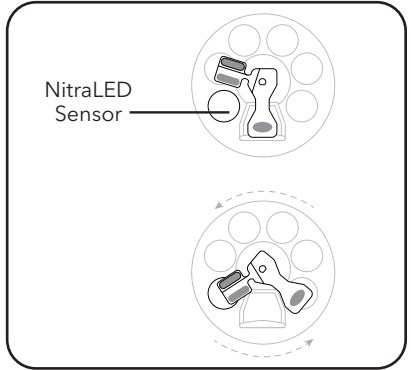

(Top view) Center Wiper Arm within NitraLED Sensor window



Make sure the Wiper Arm is fully contained within the NitraLED sensing window.

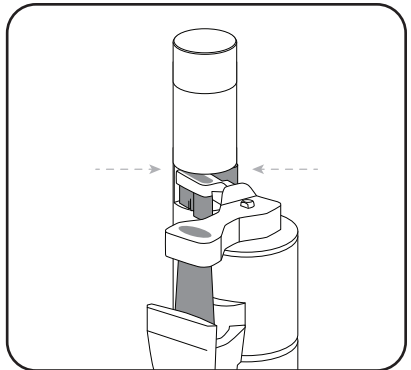

Other elements hidden to focus on the Brush and sensing window

3

In this position, tighten the set screw on the Wiper Brush using the 1/16" hex key.

There may be some resistance as the screw is designed not to back out easily.

After tightening, gently rock the brush to ensure a snug fit against the D shaft and tighten more if necessary.

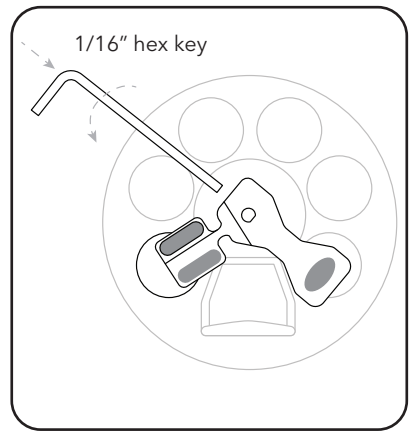

Tighten screw on back of Brush while centered in Nitrate window.

4

After the screw is tightened, manually rotate the Brush back to its home position.

NOTE: Be careful not to use too much force while rotating the brush by hand.

The main brush should be centered within the brush guard, while the Wiper Arm should be over port 5 of the EXO2 or the blank of the EXO3.

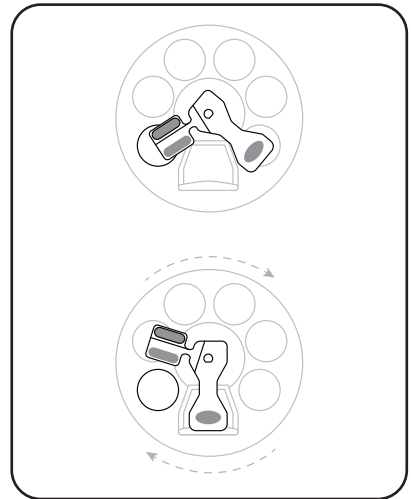

Rotate back so the main brush is over the guard.



IMPORTANT: After installing the NitraLED Wiper Brush, users must switch the **Wipe Mode** to **NitraLED** using Kor Software.

Update Wiper Settings

1

In Kor Software, make sure the Wiper Position is on.

Go to **File > Settings** and select **Wiper** to enable **Wiper Position**.

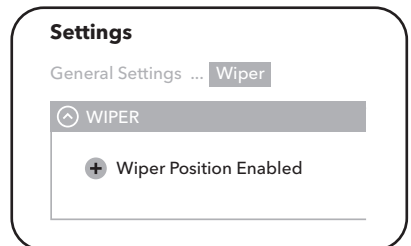

2

Also, make sure NitraLED is enabled.

Go to **File > Settings** and select **NitraLED** to enable **mg/L**.

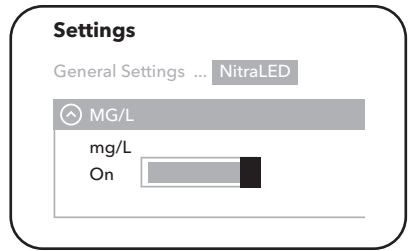

3

Go to the **Calibration** menu and select **Wiper**; then select **Calibrate**.

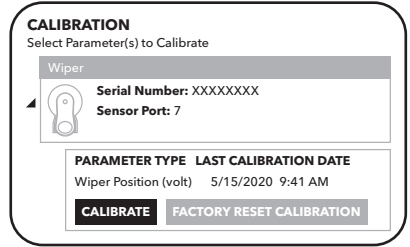

4

Enable the **NitraLED Wiper** mode and then click **Apply**.

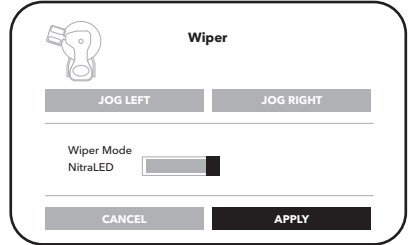

5

Go to **Live Data** and select **Start Wiping** to verify that the wiper brush effectively sweeps through the NitraLED sensor window and parks in its home position.

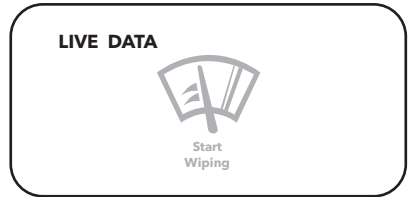

6

If the brush is off center after the wipe cycle, adjust the seating location by going to **Calibration > Wiper** then selecting **Jog Left** or **Jog Right** to ensure it is properly centered.



Contact Information



1725 Brannum Lane
 Yellow Springs, OH 45387
 (800) 765-4974, (937) 767-7241
 info@ysi.com

Visit YSI.com/EXO to find the User Manual, specs, and accessories.

Item# 608089 Dwg# 608089
 July 2020 Rev A